

REV	DESCRIPTION	DATE	EC#	APPROVE MCH MFG
A0	THIS IS PRODUCTION RELEASE	2008/04/08		XIE BI

----- REVISION -----

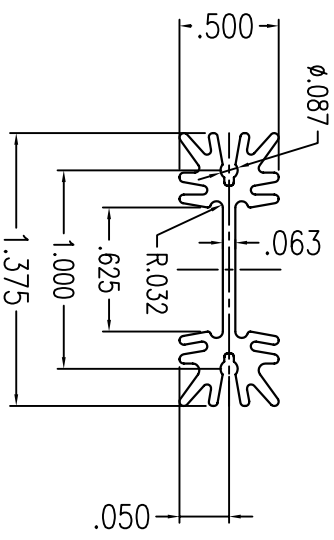
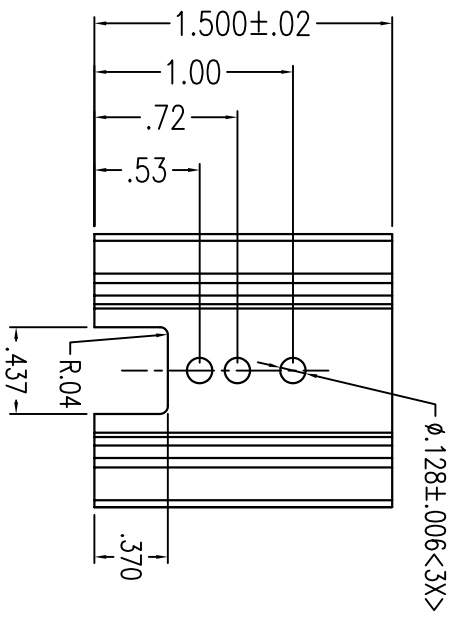

- NOTES: (UNLESS OTHERWISE SPECIFIED)
1. ALL DIMENSIONS ARE IN INCHES.
 2. REMOVE ALL BURRS AND SHARP EDGES.
 3. MATERIAL: AL 6063-T5.
 4. FINISH: BLACK ANODIZE , RoHS COMPLIANT.
 5. TOLERANCES , DECIMALS : .xx ± .015
.xxx ± .01
ANGLES: ± 3°

Jan Mao Industries Co.,Ltd

TEL:752-6860900 FAX:752-6860910

Drawing No.	D01-452-103-C	Customer PN	Checked	Unit:	Inch	Edition	REV A0
Mfg. PN	4520F3002-0A	Material	6063-T5	Engineer		Sheet	1 of 3
Description	Heat sink 1.375"*.5"*.15"	Finish	Black Anodize	Drawn	Davey xie	Scale:	1:1
						View	
						Approval	
						Date	2008/05/12

REV	DESCRIPTION	DATE	EC#	APPROVE MCH MFG
A0	THIS IS PRODUCTION RELEASE	2008/05/12		XIE BI

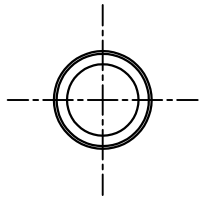
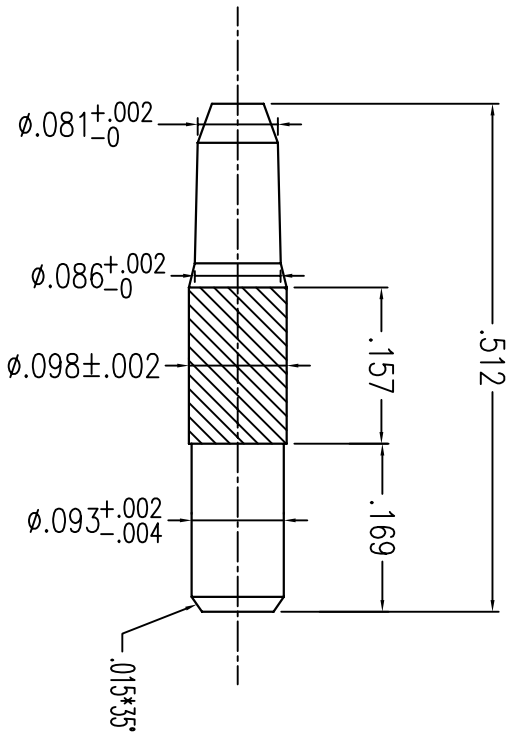

- NOTES: (UNLESS OTHERWISE SPECIFIED)
1. ALL DIMENSIONS ARE IN INCHES.
 2. REMOVE ALL BURRS AND SHARP EDGES.
 3. MATERIAL: CARBON STEEL.
 4. FINISH: NICKEL UNDERPLATE 50 UNINCHES THICKNESS, MATTE TIN, 125 TO 325 UNINCHES.
 5. TOLERANCES , DECIMALS : .xx ± .015
.xxx ± .01
ANGLES: ± 1°

Jan Mao Industries Co., Ltd TEL: 752-6860900 FAX: 752-6860910		Unit: Inch	Edition REV A0	
		Sheet 2 Of 3	View	
Drawing No.	Customer PN	Checked	Approval	
Mfg. PN	Material	Engineer	Date	2008/05/12
Description	Finish	Drown		

8	7	6	5	4	3	2	1
A	B	C	D	E	F	G	H

REV	DESCRIPTION	DATE	EC#	APPROVE
A0	THIS IS PRODUCTION RELEASE	2008-05-12		XIE BI

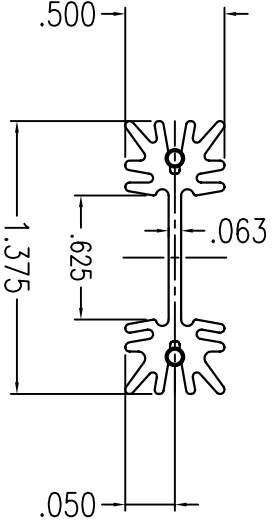
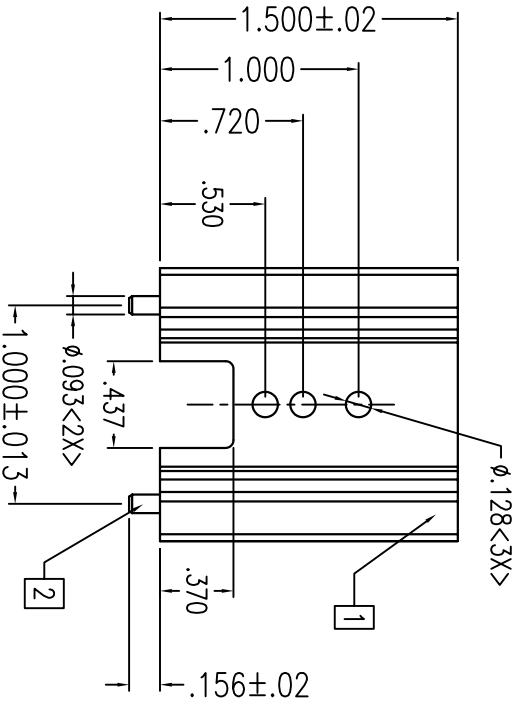

ITEM	QTY	PART NO	DESCRIPTION	MATERIAL OR MANUFACTURE
2	2	6377PIN	PIN	CARBON STEEL
1	1	HEATSINK	HEATSINK	AL 6063-T5

Jan Mao Industries Co., Ltd

TEL: 752-6860900 FAX: 752-6860910

Drawing No.	D01-452-003-C	Customer PN		Checked	
Mfg. PN	4520F3002-0A	Material	REFERENCE	Engineer	Approval
Description	HEATSINK 1.375*.5*.15"	Finish	BLACK ANODIAE	Drawn	Davey xie

Unit: Inch
Sheet 3 Of 3
Scale: 1:1
Edition REV A0
View