

--- REVISION ---			
REV	DESCRIPTION	DATE	EC#
A0	THIS IS PRODUCTION RELEASE	2007/08/03	

APPROVE	
MECH	MFG
XIE	B1

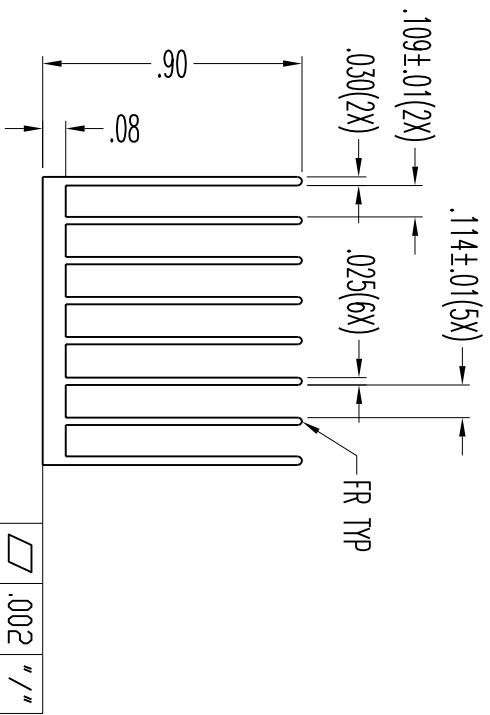
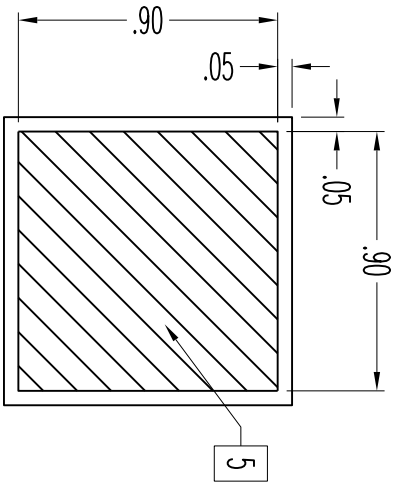
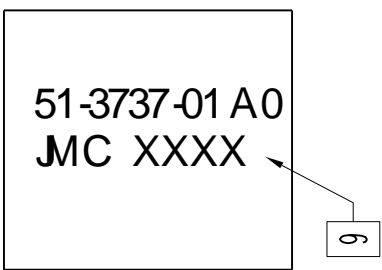
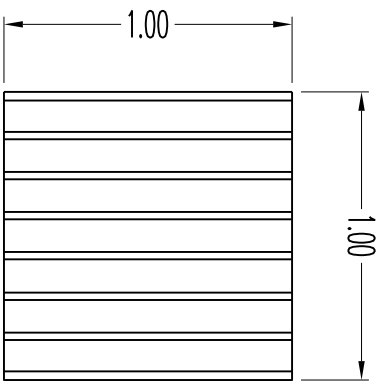

- NOTES: (UNLESS OTHERWISE SPECIFIED)
1. ALL DIMENSIONS ARE IN INCHES.
 2. REMOVE ALL BURRS AND SHARP EDGES.
 3. MATERIAL: AL 6063-T6
 4. FINISH: BLACK ANODIZE , RoHS COMPLIANT.
 5. CHDMERICS T411 INTERFACE 0.9"x0.9"
 6. MARK PART NUMBER , REVISION , VENDOR CODE , DATE CODE.
 7. TOLERANCES , DECIMALS :

.xx	.01
.xxx	.005
ANGLES:	1

Jan Mao Industries Co.,Ltd			
TEL :752-6860900 FAX :752-6860910			
Drawing No.	D01-6379-J01-C	Customer PN	51-3737-01
Mfg. PN	63790F3000-0A-A3	Material	Al 6063-T6
Description	Heatsink, 1.0"x1.0"x0.9"	Finish	Black Anodize
		Checked	Drawn
		Engineer	He Zhong
		Approval	Date
			2007-8-3
Unit:	Inch	Edition	REV A0
Sheet	1 of 1	View	
Scale:	1.5:1		