

--- REVISION ---					
REV	DESCRIPTION	DATE	EC#	APPROVE	
				MECH	MFG
A0	THIS IS PRODUCTION RELEASE	2008/04/08		XIE	BI

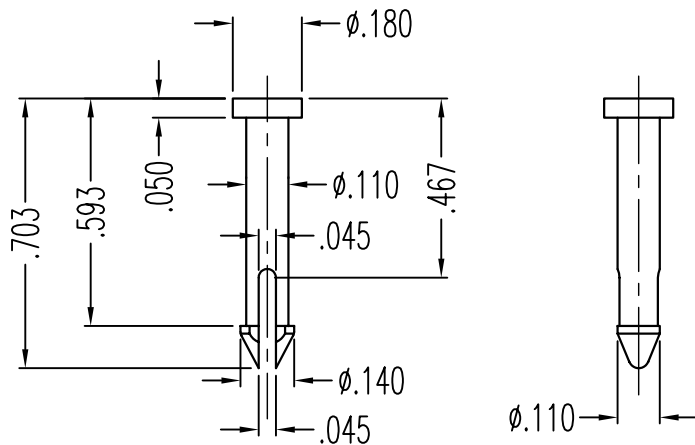

1. PUSH PIN -2 PER ASSEMBLED HEATSINK
2. MATERIAL: BRASS
3. FINISH: WASH
4. TOLERANCES , DECIMALS : .xx ± .01
.xxx ± .005
ANGLES: ± 1°

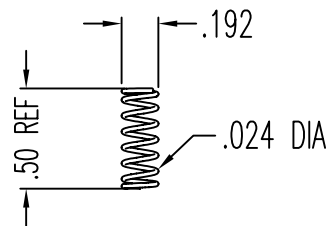

1. SPRING - 2 PER ASSEMBLED HEATSINK
2. MATERIAL: MUSIC WIRE
3. FINISH : NONE
4. SPRING PROPERTIES:
0.500" ± 0.03" FREE LENGTH
0.025" ± 0.002" WIRE DIAMETER
END: SQUARED, GROUNDING OPTIONAL
SPRING RATE: 21.8 LBF/IN ± 20%

Jan Mao Industries Co.,Ltd				Unit: Inch		Edition REV A0	
				Sheet 1 Of 1		View	
TEL:752-6860900 FAX:752-6860910				Scale: NO SCALE			
Drawing No.	D01-6658-J01-C	Customer PN		Checked		Approval	
Mfg. PN	6658 PIN	Material	NONE	Engineer			
Description	Heatsink, 0.18" x 0.703"	Finish		Drawn	Davey xie	Date	2008/04/08